

pcnautic.nl

NMEA WINDSPEED AND DIRECTION USER MANUAL



November 2007
manual 00-02.doc
Software Release 0
Hardware Version

Table of Contents

- 1 Introduction and description of fluxgate-based wind-speed and direction
 - 1.1 Description of wind direction
 - 1.2 Description of wind-speed
 - 1.3 Connections
 - 1.4 Power supply
 - 1.4.1 Power-up
- 2 Connecting to your application.
 - 2.1 To a NMEA-0183 instrument.
 - 2.2 To a PC serial port.
 - 2.3 To analogue devices
- 3 Digital Inputs and Outputs
- 4 References

1. Introduction and description of fluxgate-based wind-speed and direction

1.1 Description of Wind Direction

The wind direction is sensed by the position of a small powerful permanent magnet fixed to the rotating vane. The fin of the vane is blown by the wind so as to be on the down-wind side of the wind sensor.

The wind sensor contains a small fluxgate surrounded by high-precision interface circuits which allow a microprocessor to acquire a binary value from two orthogonal sensors of the magnetic field from the vane magnet. The magnet is strong so that the effect of the Earth's field is small enough to be negligible. The processor calculates the vector from these values and then presents the data in a manner which has been requested. Such requests alter the frequency of the data, the degree of filtering and the offset value.

It can be supplied in 2 different versions:

Digital output or Analogue output

1.2 Description of Wind-Speed

The anemometer part of the instrument contains a disc which has been made reflective on one half and not reflective on the other half of its face. An infra-red LED illuminates the disc and a phototransistor detects the reflection. By timing the changes in reflection due to the rotation of the disc the microprocessor calculates the windspeed.

1.3 Connections

Photo of connector block

Fig 2

The digital output version is connected as follows:

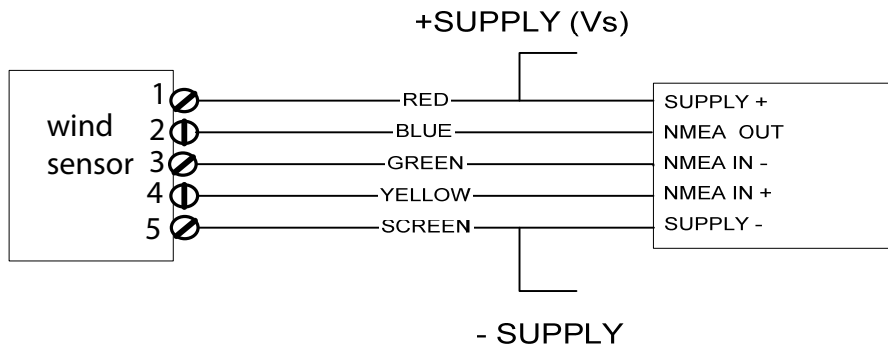

The analogue version is connected as follows:

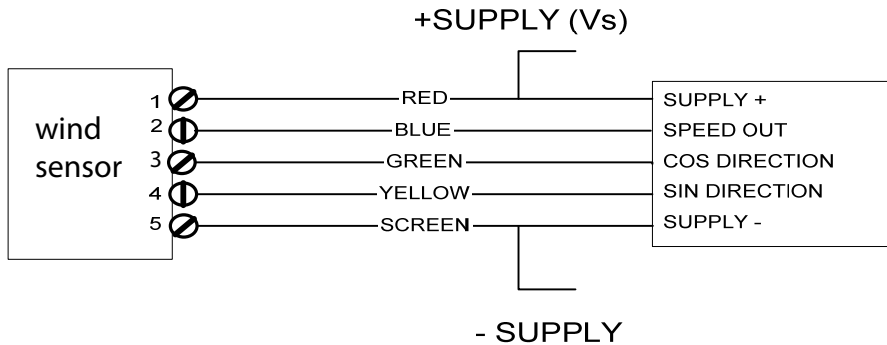

Fig 3

1.4 Power supply.

The compass is compatible with any DC power supply of between 8 and 30 Vdc. Typical supply current during operation is approx. 35mA. The Wind sensor is protected against reversed polarity.

1.4.1 Power up

When the unit is powered up full accuracy will not be achieved during the first 10 seconds of operation. The device will send **\$P<CR><LF>** on a good power-up.

Auto calibration and/or set heading operations should not be performed during this time.

This constraint does not apply after exit from sleep/shutdown mode.

2 Connecting the windsensor to your application.

2.1 To a NMEA-0183 instrument.

The hardware on which the NMEA-0183 standard is based on is a balanced serial protocol called RS422. This means that two wires are need for send and two for receive.

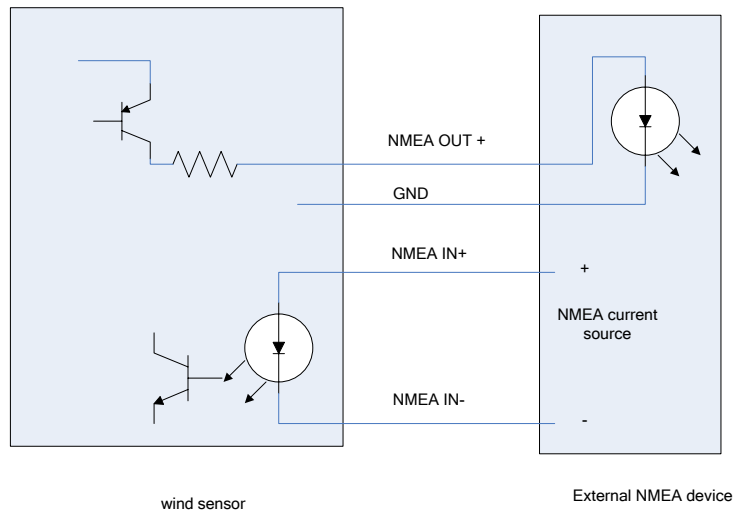

Fig 4

Note that the GND wire is used for the current return path. This might be shared with the NMEA- wire in some installations.

2.2 To a PC serial port.

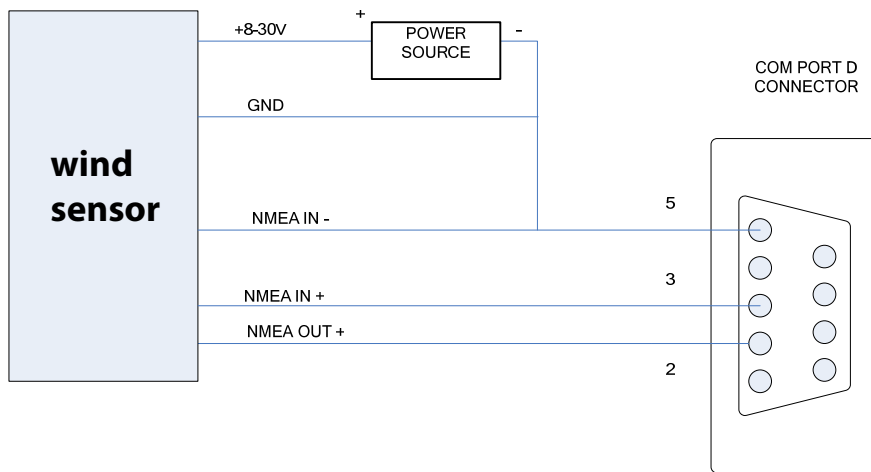

Fig 5

2.3 To Analogue devices

Using the connections shown in Fig 3, the following outputs are available as voltage levels:

Speed = 0.050 to 1.800V at 50kt
Direction Sin = $2.5 + 0.7\sin(a.a)$
Direction Cos = $2.5 + 0.7\cos(a.a)$

The user should draw no more than 100 μ A to maintain accuracy because the outputs are protected by series resistors of 100R.

3 Inputs and Output available from the wind sensor

3.1 Serial Digital

\$WIMWV,a.a,R,s.s,N,A*hhhh<CR><LF>

where **a.a** is wind angle relative to the vessel's heading, 0 to 359.9 degrees.

s.s is wind speed relative to the (moving) vessel, knots.

***hhhh** may be omitted or as two digits checksum or 4 digits unit serial number.

\$YXXDR,C,x.x,C,WND*hhhh<CR><LF>

Where **x.x** is air temperature expressed in degrees Celsius (a "-" in front of the **x.x** value indicates sub zero temperature) and **WND** is wind transducer **ID**. The sentence is transmitted every 2 seconds.

***hhhh** may be omitted or as 4 digits unit serial number.

Proprietary Output Sentence

\$PATC,WIMWV,ACK<CR><LF>

When the sensor receives any of the input sentences listed below, it replies with the acknowledge sentence except mentioned special reply sentence.

Proprietary Input Sentences

\$PATC,IIMWV,AHD,x.x<CR><LF>

Where **x.x** is the wanted reference angle, 0 to 359.9 degrees. Point the wind direction vane so that it is aligned with the forward axes of a vessel. Send this message with 0.0 as the reference direction angle. The output of the sensor will now show 0.0 degrees as the head wind direction.

\$PATC,IIMWV,DWD,x.x<CR><LF>

Where **x.x** is wind direction damping factor expressed as a percentage of from 0.0 to 100.0%. The value of 0.0 will give no damping and the value of 100% will give maximum damping.

Factory default value is 50%.

\$PATC,IIMWV,TXP,x.x<CR><LF>

Where **x.x** is the NMEA output repetition rate in milliseconds. The factory default is 90.0ms. For digital display heads a slower output rate may be preferred.

\$PATC,IIMWV,ASP,x.x<CR><LF>

Where **x.x** is the reference wind speed. This sentence is used to set the scale of the wind speed. The current wind speed is set to the value **x.x** .

\$PATC,IIMWV,ISP,x.x<CR><LF>

Where **x.x** is the wind speed integration period in milliseconds. The nominal frequency of the wind speed transducer is 1.628Hz/knot and the factory default integration period is 1000ms (1 second).

\$PATC,IIMWV,DSP,x.x<CR><LF>

Where **x.x** is speed damping expressed as a percentage of from 0.0 to 100.0%. The value of 0.0 will give no damping and the value of 100% will give maximum damping. Default value is 60%.

\$PATC,XDR,R<CR><LF>

The maximum and minimum temperature records will be set to its lowest and highest allowable values.

\$PATC,XDR,Q<CR><LF>

Request to send the maximum and minimum temperature records.

A special proprietary reply sentence as below :

\$YXXDR,Q,a.a,b.b,cc <CR><LF>

Where **a.a** is maximum recorded air temperature expressed in degrees Celsius (a “-“ in front of the **a.a** value indicates sub zero temperature).

b.b is minimum recorded air temperature expressed in degrees Celsius (a “-“ in front of the **b.b** value indicates sub zero temperature).

cc is the current Wind speed opto-sensor setting.

\$PATC,IIMWV,WSC <CR><LF>

Calibrate Wind speed opto-sensor

\$PATC,IIMWV,RID<CR><LF>

Report unit's serial number.

A special proprietary reply sentence as below :

\$PATC,WIMWV,RID,xxxx<CR><LF>, where **xxxx** is the serial number in ASCII decimal.

\$PATC,IIMWV,CFG,xy<CR><LF>

Configure unit's output sentences' structure and reply with the standard acknowledge sentence.

If **x=0**, wind direction sentence will NOT include checksum nor unit's serial number.

If **x=1**, wind direction sentence will include checksum.

If **x=2**, send unit's serial number instead of checksum.

If **y=0**, temperature sentence will NOT be sent out.

If **y=1**, temperature sentence will be sent out regularly.

If **y=2**, temperature sentence with unit's serial number will be sent out regularly.

7 References

- 1 Wind sensor datasheet
- 2 NMEA-0183 specification

pcnautic
Brinkstraat 42
7581 GD Losser
The Netherlands

tel: +31 (0) 53 430 48 54
fax: +31 (0) 53 430 48 56
e: info@pcnautic.nl
w: www.pcnautic.nl